

INSTRUCTION MANUAL FOR DIE GRINDERS

Operation Procedures

1. Connect the coupler to the air inlet ① .
2. Make sure the diameter of the collet chuck ② fits to the diameter of the grindstone with shaft.
(standard:1/4inch or 6mm option:1/8inch or 3mm).
3. Firmly insert the axis of abrasive accessories such as a grinding stone with shaft into the collet chuck ② from 15mm to 20mm depth.

4. Hold the spindle ④ with the small spanner, and firmly fasten the collet nut ③ with the big spanner.

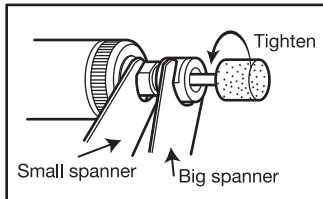

5. When the grindstone with shaft is inserted, be sure to maintain 13mm to the distance between such abrasive accessories and collet chuck, so-called the overhang.

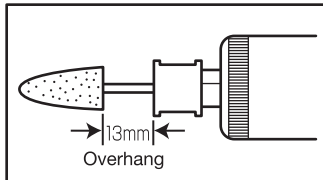

※The maximum operating speed is calculated when the overhang is 13mm.

6. Pour approx. 0.5cc (2 to 3 drops) of the oil through the coupler. Connect it to the air hose, and run for 3 to 5 seconds to circulate the oil.

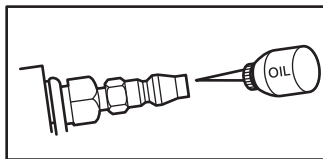

7. Before use, adjust the air regulator. Adjust the inside of the air regulator, using the driver etc. The Low speed is situated at the 90 degrees to the tool, while the High speed is done at the horizon.

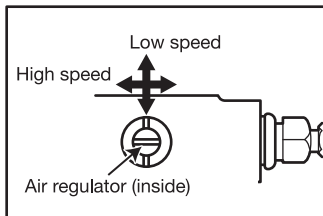

8. Take all actions to start these essential services. First, hold the safety lever lightly. Gradually raise the speed.

How to use the safety lever:

Press the stopper to the direction as indicated by arrow, and the lock is released. when freed, it is locked.

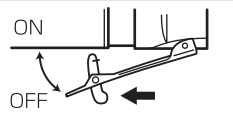

9. If the grinding stone can not be removed, slightly hit the collet nut ③ unit with a wooden hammer, spanner etc., so as not to give any damage. Then, the grinding stone will be easily removed.

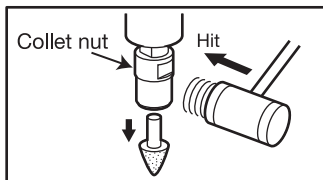

Noise Level and Vibrations

| Model Number | Noise Level dBA/(power) (ISO 3744) | Vibration m/s ² (ISO 8662) |
|--------------|--|---|
| SI-20015 | 85 / (98) | <2.5 |
| SI-20115 | 93 / (105) | <2.5 |
| SI-20065 | 89 / (101) | 3.9 |
| SI-2010 | 88 / (101) | <2.5 |

SI-20015 Max. rpm : 25,000rpm

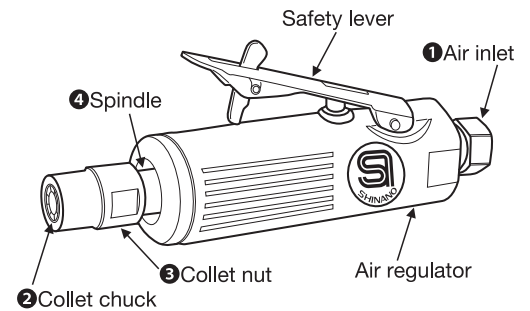

Accessories : Spanner (2),
Safety instructions (1)

SI-20115 Max. rpm : 25,000rpm

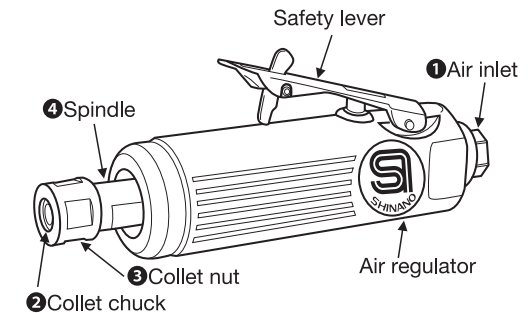

Accessories : Spanner (2),
Safety instructions (1)

SI-20065 Max. rpm : 25,000rpm

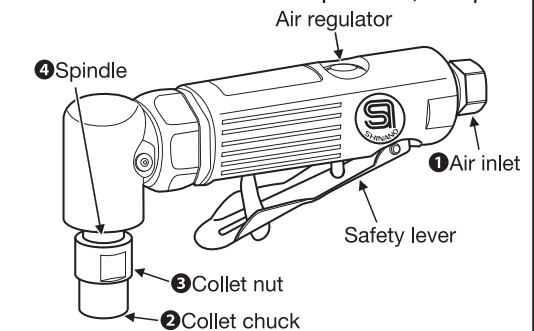

Accessories : Spanner (2),
Safety instructions (1)

SI-2010 Max. rpm : 2,500rpm

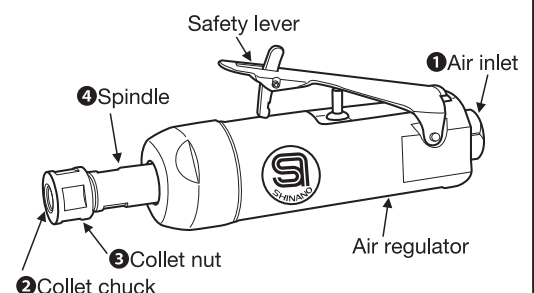

Accessories : Spanner (2),
Safety instructions (1)

WARNING

- Never use the tool beyond the maximum circumferential speed and rpm indicated on the tip tools such as grinding stones.
- The grinding stones rotates at the full speed. Therefore, if the holding power is insufficient, the abrasive accessories will burst out, which is dangerous. Firmly and securely mount it onto the collet chuck.
- Usually inspect the tool if any damage or failure such as abnormal abrasion is found on the collet chuck. If any failure is found, immediately stop operations of tool, and replace it with the normal product.
- Before use, usually inspect no split, chip, and crack is found abrasive accessories such as grinding stones.

CAUTION

- Careless drop of the tool will result in damage of the tool or components. Therefore, be sure to politely handle the tool.
- Operate the tool within the air pressure of 0.63Mpa (6.5kg/cm²). If operated in high pressure, the maximum allowance speed will be exceeded, which may result in damage of components.
- Before or after daily use, lubricate a few drops of air tool oil from the hose attached port.
- The compressed air containing dust or/and moisture will result in damage of tool. Be sure to operate the tool with air through the drainage and air filter.
- If revolution failure or/and irregular noise occurred, do not continue operation furthermore. Forced operation of tool may result in serious troubles.
- Regarding to this product, if inconvenient claims or troubles occurred, contact the product distributor.