

SI-2202

2" Disc Sander

SI-2202-2

2" Disc Sander with 2" Disc Pad

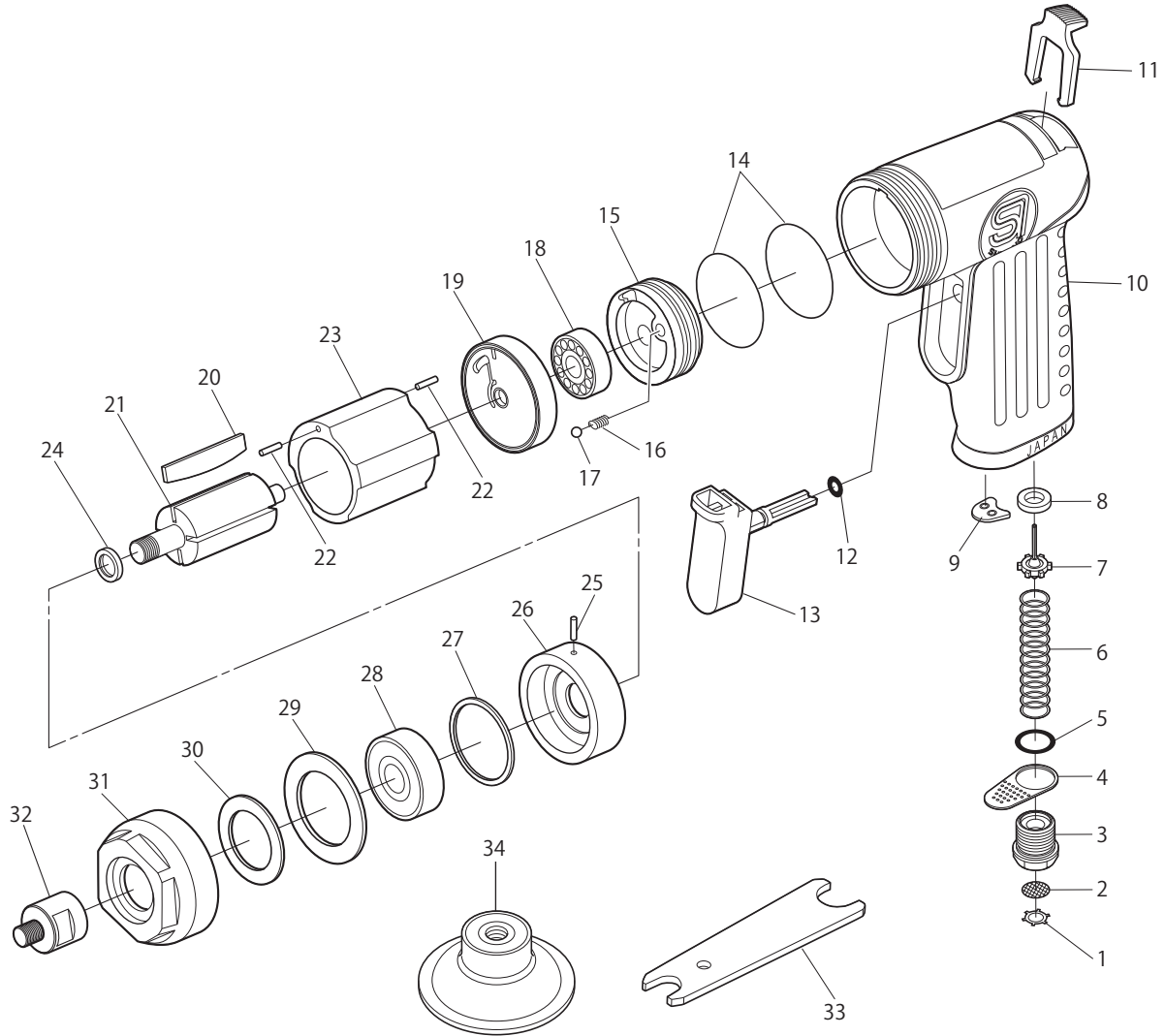

Ref. No.	Parts No.	Description	Q'ty	Ref. No.	Parts No.	Description	Q'ty
1	CRTW-12	Retainer	1	18	626	Ball Bearing	1
2	680-28A	Screen	1	19	139-14	Rear Plate	1
3	139-11	Inlet Bushing	1	20	119DP-5	Rotor Blade	4
4	139-12	Deflector	1	21	119-2	Rotor	1
5	957-3	O-Ring	1	22	15-6	Roll Pin (1.5ø-6mm)	2
6	139-15	Valve Spring	1	23	303-11	Cylinder	1
7	139-8	Valve	1	24	330-18	Collar	1
8	139-9	Valve Seat	1	25	25-3.5	Roll Pin (2.5ø-3.5mm)	1
9	139-4	Restrictor	1	26	139-5	Front Plate	1
10	139S-5	Motor Housing incl. Bush (139-20)	1	27	330-20	Shim (0.03mm)	1
11	139-3	Control Lever	1	28	608ZZ	Ball Bearing	1
12	216-6	O-Ring	1	29	670-18	Lock Washer	1
13	139S-4	Trigger	1	30	139-16	Felt Seal	1
14	210R-7	O-Ring	2	31	139-6	Lock Nut	1
15	139-2	Regulator	1	32	119-4	Spindle	1
16	960-50	Spring	1	33	330-28	Spanner Wrench (11×17mm)	1
17	SB-1/8	Steel Ball	1	★ 34	129-100	2" Disc Pad	1